

Exterior Lift System

OWNER'S MANUAL



SilverStar 
A Division of Pride Mobility Products® Corp.

SAFETY GUIDELINES

The symbols below are used throughout this owner's manual and on the product to identify warnings and important information. It is very important for you to read them and understand them completely.



WARNING! Failure to follow designated procedures can cause either personal injury, component damage, or malfunction (black symbol on yellow triangle with black border).



MANDATORY! These actions should be performed as specified. Failure to perform mandatory actions can cause injury to personnel and/or damage to equipment (white symbol on blue dot with white border).



PROHIBITED! These actions should be prohibited. These actions should not be performed at any time or in any circumstances. Performing a prohibited action can cause injury to personnel and/or damage to equipment (black symbol with red circle and red slash).

Please fill out the following information for quick reference:

Pride Provider: _____
Address: _____
Phone Number: _____
Purchase Date: _____ Serial Number: _____

NOTE: This owner's manual is compiled from the latest specifications and product information available at the time of publication. We reserve the right to make changes as they become necessary. Any changes to our products may cause slight variations between the illustrations and explanations in this manual and the product you have purchased.

Copyright © 2005
Pride Mobility Products Corp.
INFMANU3108/Rev A/August 2005

This product is manufactured by:
Silver Star Mobility
578 Mason Way
Medford, Oregon 97501

C O N T E N T S

I. INTRODUCTION.....	4
II. SAFETY	6
III. INSTALLATION	8
IV. OPERATION.....	11
V. BATTERY CHARGING.....	13
VI. CARE AND MAINTENANCE	14
VII. TROUBLESHOOTING	15
VIII. SPECIFICATIONS	16
IX. WARRANTY	17

I . I N T R O D U C T I O N

Welcome to Pride Mobility Products Corporation (Pride). Congratulations on the purchase of your new Exterior Lift System. The Exterior Lift System design combines the most advanced state-of-the-art components with modern, attractive styling. We are certain that the design features and trouble-free operation will add convenience to your daily living and ensure complete satisfaction.

At Pride, your safety is important to us. **Please read and follow all instructions in this manual before operating your lift system for the first time.** These instructions were produced for your benefit. Your understanding of these instructions is essential for the safe operation of your new lift system.

Pride is not liable for damage to property or personal injury arising out of the unsafe use of an Exterior Lift System. Pride is also not liable for any property damage or personal injury arising out of the failure of any person and/or user to follow the instructions and recommendations set forth in this manual or any other instructions or recommendations contained in other lift system related literature issued by Pride or contained on the Exterior Lift System itself.

INTERNET AND PRIVATE PURCHASES

If you purchased your product over the internet or from a previous owner and you have any questions about the safe use and/or maintenance of the product, please visit Pride's web site www.pridemobility.com or contact your authorized Pride Provider.

PURCHASER'S AGREEMENT

By accepting delivery of this product, you promise that you will not change, alter, or modify this product or remove or render inoperable or unsafe any guards, shields, or other safety features of this product; fail, refuse, or neglect to install any retrofit kits from time to time provided by Pride to enhance or preserve the safe use of this product.

INFORMATION EXCHANGE

We want to hear your questions, comments, and suggestions about this manual. We would also like to hear about the safety and reliability of your new lift system, and about the service you received from your authorized Pride Provider.

Please notify us of any change of address, so we can keep you apprised of important information about safety, new products, and new options that can increase your ability to use and enjoy your new lift system. Please feel free to contact us at the address below:

Pride Mobility Products Corporation
Attn.: Customer Care Department
182 Susquehanna Ave.
Exeter, PA 18643-2694

customercare@pridemobility.com
800.424.8205

NOTE: If you ever lose or misplace your product registration card or your copy of this manual, contact us and we will be glad to send you a new one immediately.

I . I N T R O D U C T I O N

PRIDE OWNERS CLUB

As an owner of a Pride product, you are encouraged to enroll in the Pride Owners Club. Complete and return your enclosed product registration card or visit Pride's web site at www.pridemobility.com. As a registered member, each time you visit our site, you have access to the most interactive, educational venue available today for people with mobility needs, their families, and friends.

From our home page, select "Owners Club" to enter a page dedicated to current and potential Pride product owners. You will gain access to interviews, stories, recreation ideas, daily living tips, product and funding information, and interactive message boards. These message boards invite you to communicate with other Pride customers as well as Pride representatives who are available to assist you with any questions or concerns you may have.

II. SAFETY

PRODUCT SAFETY SYMBOLS

The symbols below are used on the lift system to identify warnings, mandatory actions, and prohibited actions. It is very important for you to read and understand them completely.



Crush Hazard—Pinch/crush points created during assembly and operation. Keep hands clear.



Do not sit on mobility device while activating lift or during transport.



Crush Hazard—Moving lift can crush. Keep feet clear during operation.



Read and follow the information in the owner's manual.



Maximum lifting capacity.



Do not use as a step.



Lift system intended for use with unoccupied mobility device. Do not use product to lift people.



Removal of grounding prong can create electrical hazard. If necessary, properly install an approved 3-pronged adapter to an electrical outlet having 2-pronged plug access. Failure to heed could result in personal injury and/or property damage.

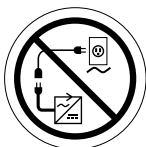

Prevent personal injury and equipment damage. Do not connect an extension cord to the charger cord.

II. SAFETY

LIFTING CAPABILITIES

The Exterior Lift System is an electromechanical device designed to lift various types of mobility devices for the purpose of vehicle transport. The Exterior Lift System is designed for a maximum Class 2 hitch allowance of 190 lbs. (86 kg) and a maximum Class 3 hitch allowance of 325 lbs. (147 kg). Under no circumstances should the Exterior Lift System be made to exceed this weight limit. Subjecting the lift system to the strain of hoisting more than it is designed to lift may cause it to fail, resulting in damage to the mobility device and/or the lift operator. Refer to the mobility device owner's manual for information on the overall weight of the mobility device before lifting.



WARNING! Adding accessories, oversize batteries, or a different seat will increase the weight of your mobility device. Verify with your authorized Pride Provider that the total weight of your mobility device, including additions, does not exceed the maximum hitch allowance.

INSTALLATION

The Exterior Lift System is designed to be mounted to a vehicle hitch system. Before lift installation, ensure that the hitch shows no signs of rust or wear and that the front and rear vehicle suspension is acceptable. If any vehicle alterations are necessary, make sure that you fully understand the instructions for drilling or cutting before making any alterations.



WARNING! Before drilling or cutting into the vehicle, make absolutely certain through visual inspection that there are no obstructions in the path of the drill bit, such as the fuel tank, exhaust pipes, or electrical wires.

LIFTING NON-PRIDE PRODUCTS

The Exterior Lift System is an extremely versatile device, which users may employ to lift items other than Pride products. Pride has no control over such use, nor can Pride anticipate every possible use to which a lift system may be put. Lifting non-Pride products with the Exterior Lift System is done at the operator's own risk, and Pride accepts no liability for damage or injury resulting from such use.

PRELIFT INSPECTION

Before operating the Exterior Lift System, inspect your surroundings to ensure that the lift system has a clear path of operation. Remove any possible obstructions before operating the lift and do not allow children to operate or play near the lift.

OPERATOR POSITIONING

The operator of the lift should stand a safe distance from the unit being lifted/lowered to ensure that his/her feet are never positioned under the raised lift platform. The operator should also keep his/her hands clear of the lift system to avoid the potential for injury.

TRANSPORT VEHICLE POSITIONING

Be sure your vehicle is parked on flat, level ground before attempting to load, lift, or remove a mobility device with the Exterior Lift System. Make sure the vehicle emergency park brake is engaged before loading or unloading a mobility device.

III. INSTALLATION

EXTERIOR LIFT SYSTEM INSTALLATION

The Exterior Lift System is designed to be easily installed into any vehicle equipped with a Class 2 or Class 3 hitch receiver. The hitch receiver should be installed no higher than 20 in. (50.8 cm) from the bottom of the hitch tube to the ground.

NOTE: Once installed, the lift system may obstruct the view of the vehicle license plate. Research the local laws for license plate obstruction in your area and install the optional license plate kit if necessary. Contact your authorized Pride Provider for more information.



WARNING! Prevent product and/or vehicle damage! The Exterior Lift should be installed by an authorized service technician only.

Follow these steps to install the Exterior Lift System:

1. Remove the pre-assembled mounting hardware from the hitch tube.
2. Position the mechanical switch along the driver's side of the hitch tube. See figure 1.



WARNING! Do not modify the mechanical switch in any way not authorized by Pride. Unauthorized modifications may void your warranty and result in product damage.

3. Mount the mechanical switch and hitch tube to the lift frame using the previously removed mounting hardware. See figure 1.
4. Slide the hitch tube into the vehicle hitch receiver, aligning the mounting hole closest to the lift with the mounting hole in the hitch receiver. See figure 2.



WARNING! Lifting weight beyond your physical capability can result in personal injury. Ask for assistance if necessary when attaching the lift frame to the hitch receiver.

WARNING! Avoid pinch points! Do not hold the lift frame by the pivot points when mounting the lift frame to the hitch receiver.

5. Secure the hitch tube with the supplied bolt and nut, inserting the bolt from the passenger's side through to the driver's side of the hitch. See figure 2.



WARNING! Threading the bolt from the wrong side or allowing the bolt to turn while tightening the nut will dislodge the threaded insert in the hitch tube.

WARNING! Do not attach a Class 2 hitch tube to a Class 3 hitch receiver. Personal injury or product damage may result.

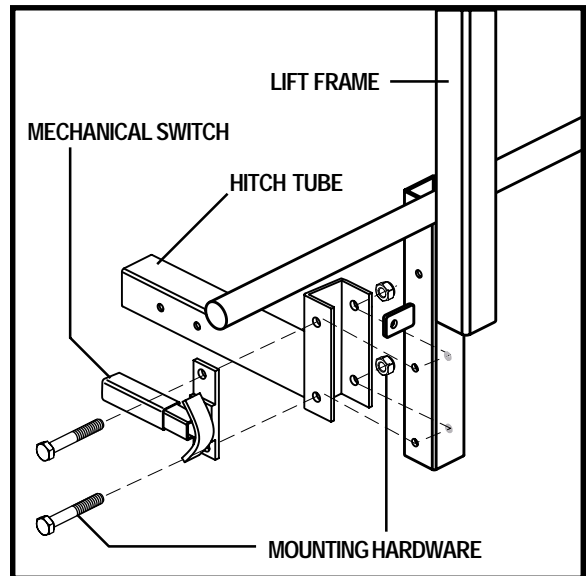

Figure 1. Hitch Tube Assembly

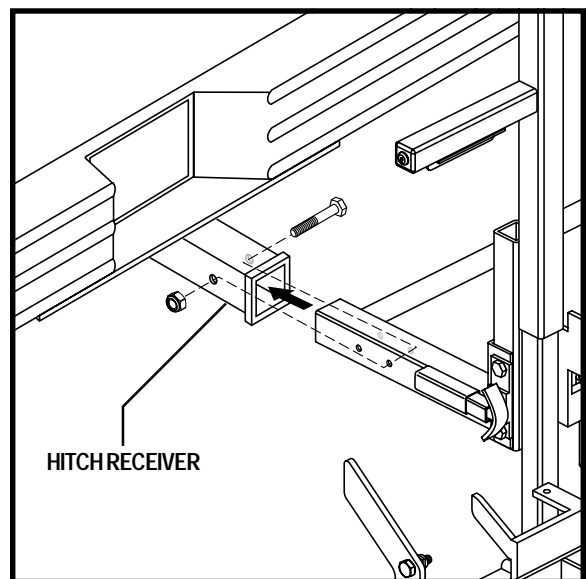

Figure 2. Lift Frame Vehicle Mounting

III. INSTALLATION

NOTE: Make sure the hitch bolt is tightened firmly before securing the nut to the hitch assembly to minimize the chance that the lift will tilt during transport.

NOTE: Make sure the hitch tube and lift platform are parallel to the ground before operating the lift system. An angled hitch tube may cause unreliable lift operation and/or damage to the lift system.

6. Route the lift system wiring harness through the vehicle. Refer to “Wiring Harness Installation.”



WARNING! Prevent product damage! Route the wiring harness through the vehicle rather than under the vehicle to avoid coming in contact with sharp edges, extreme temperatures, moving parts, and roadway debris. Power shorts may occur if wires come in contact with hot exhaust parts or sharp edges.

WARNING! Never attach the wiring harness to a secondary power source. Do not attempt to use trailer wiring to power the lift system. The wiring harness must be connected directly to the vehicle battery.

NOTE: If your lift is equipped with an onboard battery, refer to “Onboard Battery Installation.”

7. Install the lift platform kit. Refer to the instructions supplied with the kit.

Wiring Harness Installation

The wiring harness is approximately 25 ft. (7.62 meters) long and will accommodate most vehicles.

NOTE: You may wish to perform a practice run before installing the wiring harness. Route a piece of light rope (equivalent to the gage of the wiring harness) along the anticipated path observing contact points, potential rubbing/chafing points, and any sharp edges. Remove sharp edges with a fine grade file, then treat the steel with a rust inhibitor or metal sealant.

Follow these steps to route the Exterior Lift System wiring harness:

1. Route the lift system wiring harness (starting at the lift) through the interior of the vehicle until you reach the automobile battery. See figure 3. You will typically find pass through points at the rear lighting assemblies, which will enable you to route the cable through the trunk and under the back seat.

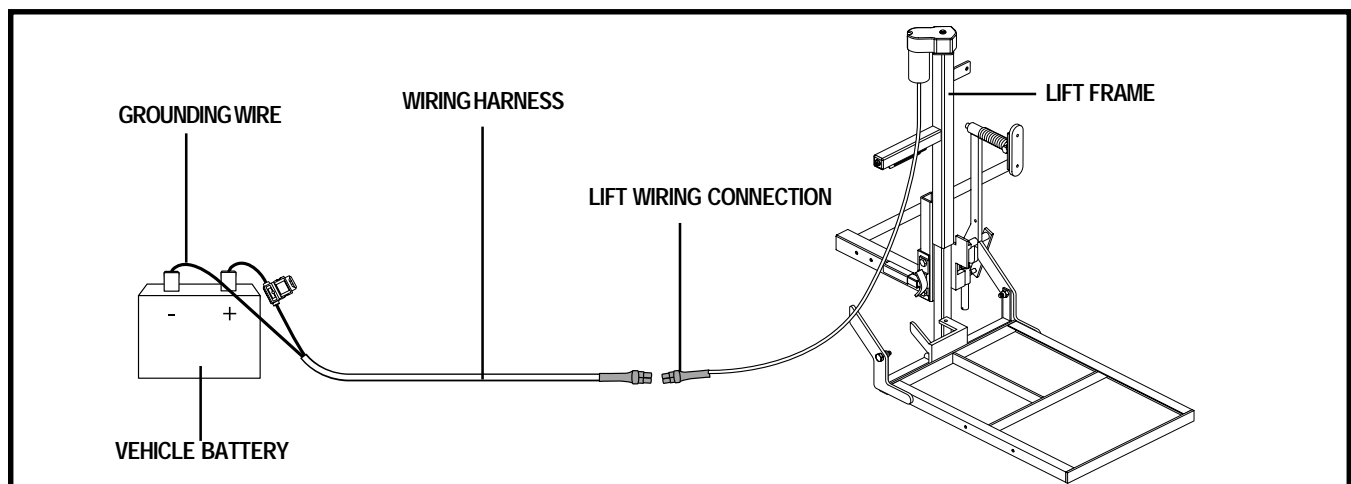

Figure 3. Wiring Harness Installation

III. INSTALLATION

2. Conceal the harness behind or under the interior panels of the vehicle (there should be existing holes). Be certain that the harness is protected with a rubber grommet when passing it through the metal panels and into the engine compartment.
3. Inside the engine compartment, secure the harness to the firewall and the inner fender with plastic wire ties. Use care not to cause abrasions to the wiring harness. It is important to secure the wiring harness at various points along its run of the vehicle.



WARNING! Do not cut or shorten the wiring harness. If the harness is too long, coil the excess wire and secure it with plastic wire ties.

4. Connect the red wire to the positive (+) terminal and the black (grounding) wire to the negative (-) terminal of the vehicle battery.



WARNING! Before operating the lift, inspect the wiring harness for proper routing and grounding. Improper routing can cause damage to the harness, and improper grounding can cause damage to the electrical system.

Onboard Battery Installation

The optional onboard battery is designed for easy installation as it does not require any wires to be routed through or under the vehicle.

Follow these steps to install the onboard battery:

1. Align the mounting holes in the battery case bracket with those in the accessory bracket located under the key switch tube. See figure 4.
2. Secure the battery case to the accessory bracket with the supplied hardware. See figure 4.
3. Insert the onboard battery into the battery case, making sure that the connector on the bottom of the battery aligns and fully connects with the mating connector inside the battery case.
4. Plug the battery cord on the bottom of the battery case into the mating connector running from the motor. See figure 4.

Automatic Lock-down Arm Installation

The automatic lock-down arm is a safety feature designed to secure scooters to the lift platform during vehicle transport. The automatic lock-down arm will come fully assembled. In order to secure it to the frame, align the lock-down arm bracket with the holes at the back of the lift frame under the tilt bar and install the supplied hardware to lock the assembly in place. See figure 5.

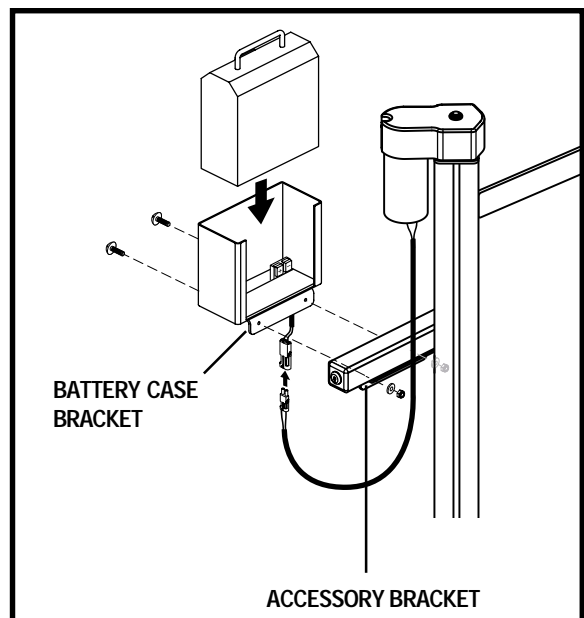

Figure 4. Onboard Battery Installation

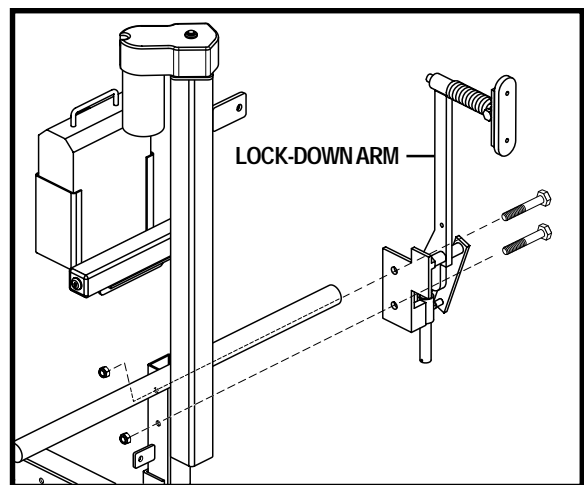

Figure 5. Automatic Lock-down Arm Installation

IV. OPERATION

EXTERIOR LIFT SYSTEM OPERATION

WARNING! The Exterior Lift System is intended for the transport of mobility devices only. The mobility device must be unoccupied before operating the lift.



WARNING! Prevent vehicle damage! Do not exceed the load limits of your vehicle or hitch system as specified by the vehicle manufacturer.

WARNING! Use extreme caution when driving with the lift installed on your vehicle. Be aware that the lift extends away from the back of the vehicle and extra clearance is needed when backing up, turning, parking, or driving through driveway entrances/exits. Drive slowly when negotiating pot holes, road bumps, and railroad tracks.

Follow these steps to operate the Exterior Lift System:

1. Insert the key into the key switch.
2. Turn and hold the key clockwise to lower the lift platform. See figure 6. Release the key as soon as the lift platform touches the ground.
3. Set the speed control to the slowest setting and carefully drive your mobility device onto the lift platform, being sure to center the mobility device on the platform to the best of your ability.

NOTE: You may wish to load the mobility device while standing next to it using the manual freewheel feature. Refer to the mobility device owner's manual for more information on manual freewheel mode.

4. Shut down the power to the mobility device, remove the key if applicable, and make sure the unit is in drive mode (drive motors engaged). Refer to the mobility device owner's manual for more information on drive mode.



WARNING! Never leave a mobility device in manual freewheel mode during lift system transport. The mobility device could roll, resulting in personal injury and product damage.

5. Secure the mobility device to the platform using either the tie-down straps for power chairs or the automatic lock-down arm for scooters. Drape the tie-down straps tightly over the seat and secure the straps to the platform, ensuring that there is no excess slack over the seat. See figure 7.



WARNING! Prevent product damage! Never attempt to secure the tie-down straps over the seatback or armrests of a power chair.

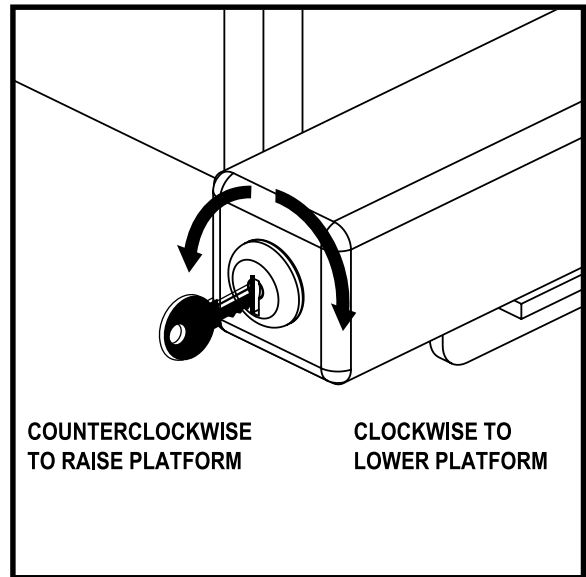

Figure 6. Key Switch Operation

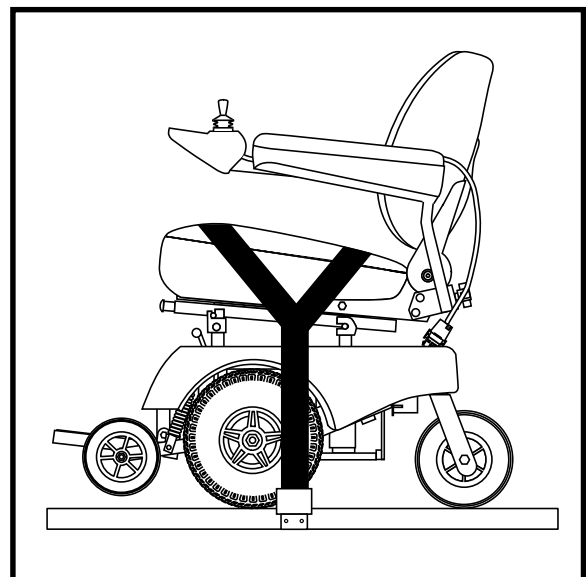

Figure 7. Tie-down Strap Placement

IV. OPERATION

WARNING! For lift systems equipped with the automatic lock-down arm, do not attempt to adjust the pressure of the arm. This feature has been configured by your authorized Pride Provider to meet your needs and requires no further adjustment.



WARNING! If your scooter is equipped with pneumatic drive tires, make sure the tires are inflated to the recommended pressure labeled on the tire sidewall. This will ensure that the scooter is at the correct deck height for proper lock-down arm positioning.

NOTE: Inspect the tie-down straps before each use to ensure there are no signs of fraying or wear. Ensure that the mobility device is secured properly before transport. Pride is not liable for damage or loss resulting from improper securing of a mobility device.

6. Turn and hold the key counterclockwise to raise the lift. See figure 7. Continue to raise the lift until the motor stops, then release the key.

NOTE: As the lift platform rises, the automatic lock-down arm activates to secure the scooter to the lift platform. You may need to adjust the scooter tiller position to prevent interference with the smooth operation of the automatic lock-down arm.

NOTE: The motor will stop automatically at the top of its stroke and will emit a clicking sound. Release the key immediately upon hearing this sound, then turn the key counterclockwise one more time for no more than 2 seconds to ensure the platform is in the fully raised position.

NOTE: Pay attention to the path of the lift platform during operation. Make sure the lift does not rub against or interfere with the vehicle in any way. If you notice any contact between the lift platform and the vehicle, stop lift operation immediately and contact your authorized Pride Provider for assistance.

Follow these steps to remove a mobility device from the Exterior Lift System:

1. Lower the lift platform to the ground.
2. Unfasten the tie-down straps or lift the lock-down arm to the vertical position.
3. Unload the mobility device from the lift platform.
4. Raise the lift platform for storage, noting that it will automatically fold into a stowed position.
5. Remove the key from the lift system when it is not in use.

WARNING! Prevent product damage! Place the lock-down arm in the vertical position before stowing the lift platform.



WARNING! Do not attempt to manually pull the lift platform down from the stowed position. Doing so will result in product damage and will void the product warranty.

MANUAL EXTERIOR LIFT OPERATION

The lift system is equipped with a manual crank that serves as backup in the event of a power failure. Using the supplied tool, rotate the manual crank (located on top of the motor housing) clockwise or counterclockwise to move the platform up or down. See figure 8.

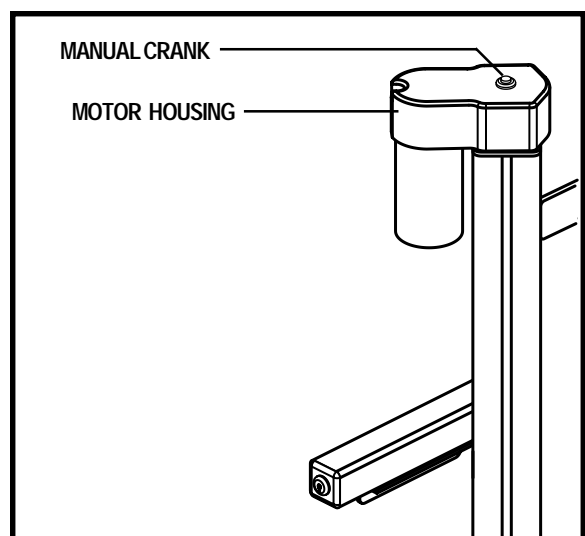

Figure 8. Manual Crank Operation

V. BATTERY CHARGING

BATTERY CHARGING

Follow these steps to charge the onboard battery:

1. Remove the onboard battery from the battery case and place it near a standard electrical wall outlet.
2. Plug the charger cord into the socket located on the bottom of the battery, then connect the charger cord to a standard electrical outlet. See figure 9.



PROHIBITED! Never use an extension cord to plug in your charger cord. Plug the charger cord directly into a properly wired standard wall outlet.



PROHIBITED! Removal of the grounding prong can create an electrical hazard. If necessary, properly install an approved 3-pronged adapter to an electrical outlet having 2-pronged plug access. Failure to heed could result in personal injury and/or property damage.



WARNING! Prevent component damage! Do not attempt to charge the battery and operate the lift system at the same time.

WARNING! Prevent component damage! Do not attempt to wire the lift system directly to the vehicle battery if the lift system is equipped with an onboard battery.

NOTE: *It is recommended that you replace the battery every 3–5 years. Store the battery in a moisture-free environment when not in use.*

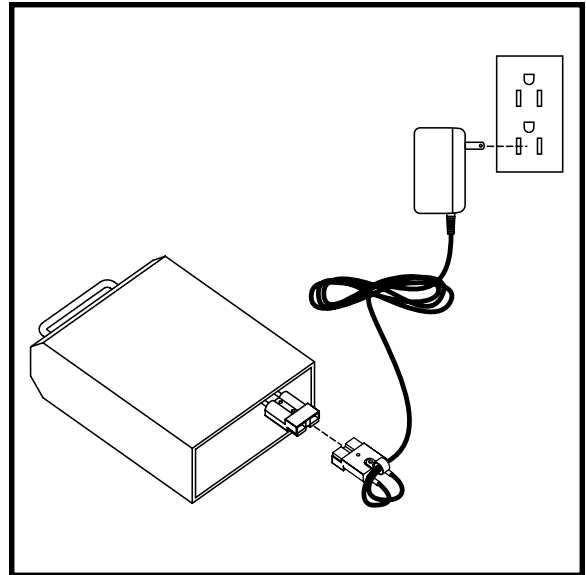

Figure 9. Battery Charging

V I . C A R E A N D M A I N T E N A N C E

CARE AND MAINTENANCE

Your lift system requires a minimal amount of care and maintenance. If you do not feel confident in your ability to perform the maintenance listed below, you may schedule inspection and maintenance at your authorized Pride Provider. The following areas require periodic inspection and/or care and maintenance.

90-Day Maintenance Schedule

- Lower the platform to the ground, clean away any remnants of old grease from the T-bar inner-telescoping tube, and apply a new coat of all-weather lithium grease to the inner-telescoping tube. See figure 10.
- Apply all-weather lithium grease to the pivot points of the T-bar.
- Lubricate the key switch with an electrical-type lubricant (not WD-40).
- Remove the vehicle battery connections and clean them to ensure uninterrupted electronic connection.
- Torque the hitch bolt.
- Check the lift system for loose or damaged parts. Have your authorized Pride Provider repair or replace any problem parts before using the lift system.

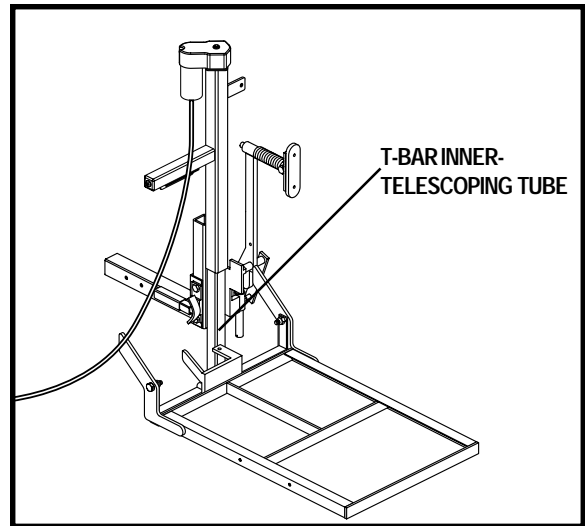

Figure 10. Lift Frame Maintenance

General Cleaning Guidelines

The lift system can be hand washed along with the vehicle with soap and water. However, automatic drive-through car washes should be avoided as they may interfere with and cause damage to the lift.

Wiring Harness

The wiring harness should be checked periodically for corrosion and/or decay. Contact your authorized Pride Provider if the wiring harness needs to be replaced.

Lift Platform/Metal Components

- Check the lift platform for wear or damage. Contact your authorized Pride Provider for repair or replacement.
- The lift platform surface may become slippery if exposed to moisture (ice, snow, rain, mist/spray conditions, etc.). Use caution when loading/unloading a mobility device in these conditions and wipe off any excess moisture from the lift platform.
- Regularly inspect the metal lift components for scratches. Treat any problem areas with a rust inhibitor or metal sealant.

If your lift system is exhibiting wear that you feel is questionable in any way, contact your authorized Pride Provider immediately. Do not attempt to repair, adjust, or modify the manufacturer settings and materials.

VII. TROUBLESHOOTING

TROUBLESHOOTING

Any electromechanical device occasionally requires some troubleshooting. However, most of the problems that may arise can usually be solved with a bit of thought and common sense. Many of these problems occur because the battery is not fully charged or because the battery is worn down and can no longer hold a charge.

What if the motor on my lift system will not operate?

- Make sure the onboard battery or vehicle battery is fully charged.
- Make sure all connections to the motor and battery are secure.
- Check the wiring harness for signs of wear or decay. Replace the harness if necessary.

What if the lift system operates slowly up or down?

- Make sure the onboard battery or vehicle battery is fully charged.
- Make sure all connections to the motor and battery are secure.
- Check the wiring harness for signs of wear or decay. Replace the harness if necessary.

What if the lift platform does not fold into the stowed position?

Check to make sure there are no obstructions in the T-bar pivot points.

What if the lift platform does not lower completely to the ground?

- Verify that the hitch receiver is at the proper height. The distance from the bottom of the hitch to the ground should not exceed 20 in. (50.8 cm).
- Check to make sure that the area under the lift platform is free from obstructions.

What if the lift bottoms out when driving over bumps or driveway entrances?

Verify that the hitch receiver is at the proper height. The distance from the bottom of the hitch to the ground should be 20 in. (50.8 cm).

VIII. SPECIFICATIONS

SPECIFICATIONS	
Lift System Dimensions	Overall Height: 41 in. (104 cm) Overall Width: 40–43 in. (101.6–109.25 cm) from hitch with platform down 16–19 in. (40.6–48.26 cm) from hitch with platform folded Platform Width: 28 in. (71 cm)
Maximum Lift Capacity	190 lbs. (86 kg) with Class 2 hitch 325 lbs. (147 kg) with Class 3 or higher hitch
Maximum Mobility Device Width	27 in. (68.58 cm)
Maximum Hitch-to-Ground Clearance	20 in. (50.8 cm)
Motor	Fully sealed, 12-volt DC
Onboard Battery	12-volt, 18 AH
Charger	110-volt, off-board

IX . WARRANTY

THREE-YEAR TRANSFERABLE LIMITED WARRANTY

For three (3) years from the date of purchase, Pride Mobility Products will repair or replace at our option, free of charge, any mechanical or electrical component found upon examination by an authorized representative of Pride to be defective in material and/or workmanship.

This warranty does not extend to those items, which may require replacement due to normal wear and tear.

- Labor, service calls, shipping, and other charges incurred for repair of the product, unless specifically authorized by Pride Mobility Products Corporation IN ADVANCE, are excluded.

Exclusions also include components with damage caused by:

- Contamination
- Abuse, misuse, accident, or negligence
- Battery fluid spillage or leakage
- Commercial use, or use other than normal
- Improper operation, maintenance, or storage
- Repairs and/or modifications made to any part without specific consent from Pride Mobility Products Corporation.
- Circumstances beyond the control of Pride

ONE-YEAR WARRANTY

The battery is covered by a separate one (1) year warranty provided by the battery manufacturer. The batteries are not warranted by Pride Mobility Products Corporation.

SERVICE CHECKS AND WARRANTY SERVICE

An authorized Pride Mobility Products Provider must perform warranty service. Do not return faulty parts to Pride Mobility Products without prior written authorization. All transportation costs and shipping damage incurred while submitting parts for repair or replacement is the responsibility of the purchaser.

Failure to follow the instructions, warnings, and notes in the owner's manual and those located on your Pride lift product can result in personal injury or product damage and will void Pride's product warranty.

There is no other express warranty.

IMPLIED WARRANTIES

Implied warranties, including those of merchantability and fitness for a particular purpose, are limited to one (1) year from the date of purchase and to the extent permitted by law. Any and all implied warranties are excluded. This is the exclusive remedy. Liabilities for consequential damages under any and all warranties are excluded.

Some states do not allow limitations on how long an implied warranty lasts or do not allow the exclusion of limitation incidental or consequential damages. The above limitation or exclusion may not apply to you.

This warranty gives you specific rights, and you may also have other rights, which vary from state to state.

Please fill out and return the product registration card to Pride Mobility Products. This will aid Pride in providing the best possible technical and customer service.

NOTES



578 Mason Way
Medford, OR 97501
www.silverstarmobility.com